



## SL Series

- High ripple current, suitable to use in industrial power supplies for inverter circuitry, etc
- Load life 20,000 hours at 85°C



### ◆ SPECIFICATIONS

Item	Performance Characteristics	
Category Temperature Range	-40 ~ +85°C	-25 ~ +85°C
Working Voltage Range	200 ~ 250Vdc	350 ~ 400Vdc
Capacitance Range	1,500 ~ 39,000μF	1,000 ~ 15,000μF
Capacitance Tolerance	±20% (at 25°C and 120Hz)	
Dissipation Factor (tanδ) (at 25°C, 120Hz)	Rated Voltage (V)	200      250      350      400
	tanδ(Max)	0.25    0.25    0.20    0.20
Leakage Current	I=0.01CV or 5000μA, whichever is smaller I : Leakage current (μA)    C : Rated capacitance (μF)    V : Rated voltage (V) Impress the rated voltage for 5 minutes	
Endurance	The following specifications shall be satisfied when the capacitors are restored to 25°C after subjected to DC voltage with the rated ripple current is applied for 20,000 hours at 85°C	
Shelf Life	Capacitance change	≒ ±20% of the initial value
	Dissipation factor(tanδ)	≒ 200% of the specified value
	Leakage current	≒ specified value
Others	The following requirements shall be satisfied when the capacitor are restored to 25°C after the rated voltage applied for 500 hours at 85°C without voltage applied.	
	Conforms to JIS-C-5101-4 (1998), characteristic W	

### ◆ DIMENSIONS (mm)

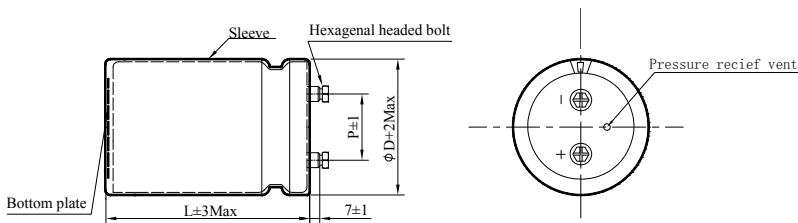

ΦD	51	64	76	90
P±1	22.4	28.0	31.5	31.5

### ◆ PART NUMBER SYSTEM ( Example : 350V 15000μF )

S L 2 V 1 5 3 M L S 9 0 N 0

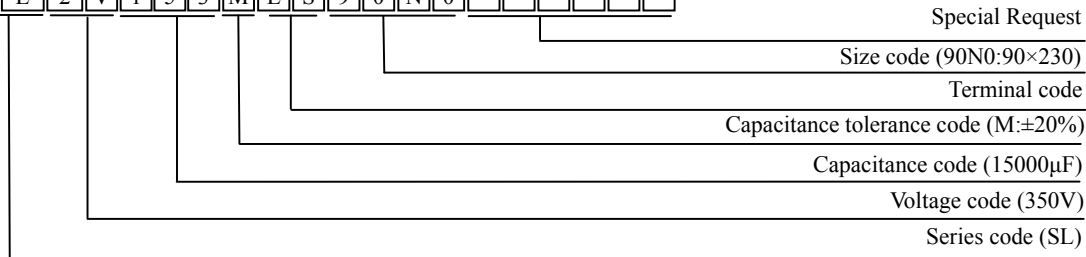



**SL Series**

◆ **Case size & Permissible rated ripple current (A rms) 120Hz / 85°C**

Vdc ΦD uF	200								250							
	Φ51		Φ64		Φ76		Φ90		Φ51		Φ64		Φ76		Φ90	
	ΦD×L	RC	ΦD×L	RC	ΦD×L	RC	ΦD×L	RC	ΦD×L	RC	ΦD×L	RC	ΦD×L	RC	ΦD×L	RC
1500									51×80	2.4						
1800									51×100	2.8						
2200	51×80	2.9							51×100	3.2	64×80	3.0				
2700	51×100	3.4							51×120	3.7	64×80	3.6				
3300	51×100	3.9	64×80	3.7					51×120	4.4	64×100	4.3				
3900	51×120	4.6	64×100	4.4							64×100	5.0				
4700			64×100	5.1							64×120	5.9	76×100	5.6		
5600			64×120	6.1							64×120	6.6	76×100	6.4		
6800			64×120	7.2	76×100	7.0					64×150	7.3	76×120	7.1		
8200			64×120	7.9	76×100	7.6					64×150	8.9	76×120	8.6		
10000			64×150	8.5	76×120	8.2							76×150	10.0	90×120	9.6
12000					76×120	9.3	90×100	8.9					76×190	11.5	90×150	11.1
15000					76×150	10.4	90×120	9.9							90×170	12.7
18000					76×170	13.2	90×120	12.7							90×190	14.1
22000					76×190	15.7	90×150	15.1							90×230	15.4
27000					76×190	15.7	90×150	15.1								
33000							90×190	15.9								
39000							90×230	18.0								

Vdc ΦD uF	350								400							
	Φ51		Φ64		Φ76		Φ90		Φ51		Φ64		Φ76		Φ90	
	ΦD×L	RC	ΦD×L	RC	ΦD×L	RC	ΦD×L	RC	ΦD×L	RC	ΦD×L	RC	ΦD×L	RC	ΦD×L	RC
1000	51×80	3.9							51×80	3.9						
1200	51×80	4.2							51×100	4.6	64×80	4.2				
1500	51×100	5.2							51×120	5.6	64×80	6.0				
1800	51×100	5.7	64×80	5.4					51×120	6.4	64×100	5.2				
2200	51×120	7.1	64×100	6.7							64×100	6.9				
2700			64×100	7.7							64×120	8.2	76×100	7.7		
3300			64×120	9.1							64×120	9.5	76×100	9.0		
3900			64×120	10.4	76×100	9.8					64×150	11.1	76×120	10.5	90×100	9.9
4700			64×150	12.2	76×120	11.5							76×120	12.0	90×100	11.4
5600					76×120	13.1	90×100	12.4					76×150	14.0	90×120	13.3
6800					76×150	15.5	90×120	14.7					76×190	17.3	90×150	16.5
8200					76×170	19.0	90×150	18.1							90×170	18.1
10000					76×190	20.9	90×150	19.9							90×190	21.7
12000							90×190	23.8							90×230	25.8
15000							90×230	28.8								

◆ **RIPPLE CURRENT MULTIPLIERS**

**Frequency Multipliers**

Vdc	Frequency (Hz)				
	60	120	360	1K	10K
200 ~ 400	0.70	1.00	1.10	1.30	1.40

# SL Series

◆ DIMENSIONS (Screw-Mount) [mm]:

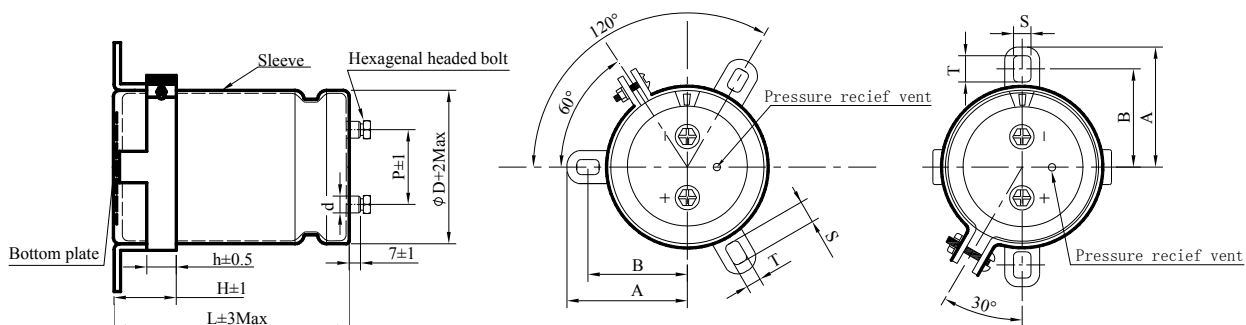

◆ Terminal pitch and Nominal dia. of bolt

Terminal Code	$\phi D$	$P \pm 1$	Nominal dia. of bolt	$d \pm 0.5$
LS	51	22.4	M5	10
	64	28.0	M5	10
	76	31.5	M5	10
	90	31.5	M5	10
LA	64	28.0	M5	13
	76	31.5	M5	13
	90	31.5	M5	13
LB	76	31.5	M6	17
	90	31.5	M6	17

◆ Dimensions of mounting bracket

Leg shape	D	$A \pm 2$	$B \pm 1$	$T \pm 0.5$	$S \pm 0.5$	$H \pm 1$	$h \pm 0.5$
2 – Leg (Code:K1)	51	40.0	34.0	7.0	5.0	30	24
	64	46.5	40.5	7.0	5.0	30	24
	76	53.0	46.8	7.0	5.0	30	24
	90	60.3	54.0	7.0	5.0	35	20
3 – Leg (Code:K2)	51	36.5	31.8	7.0	5.0	30	24
	64	43.6	38.1	7.0	5.0	30	24
	76	50.2	44.5	7.0	5.0	30	24
	90	56.5	50.8	7.0	5.0	30	24